



SUPER-FGD FOR ND280 UPGRADE OF THE T2K EXPERIMENT

Haowei Zheng

EPAP Seminar, King's College London

Feb 20, 2026

TABLE OF CONTENTS

- T2K Experiment & ND280 Upgrade
- Super-FGD concept, prototype & design
- Assembly & Commissioning
- Electronics & Calibration
- Detector Performance

THE T2K EXPERIMENT

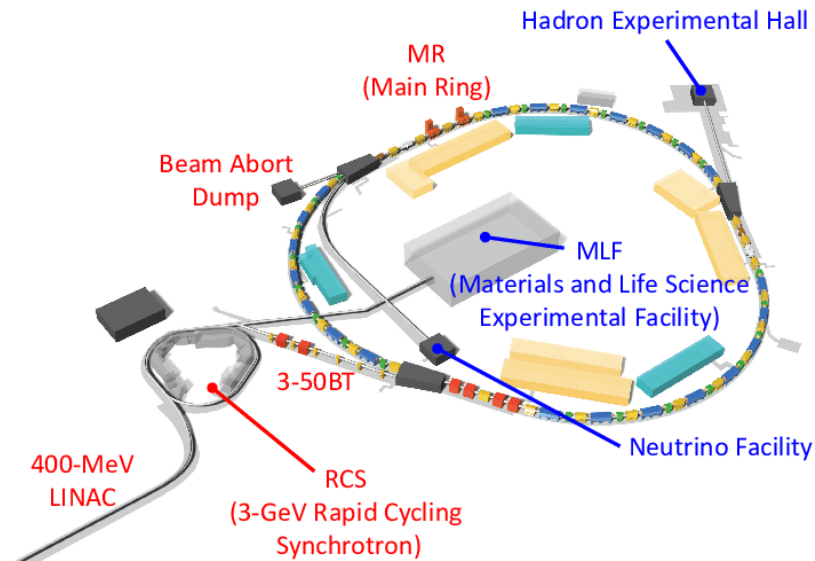
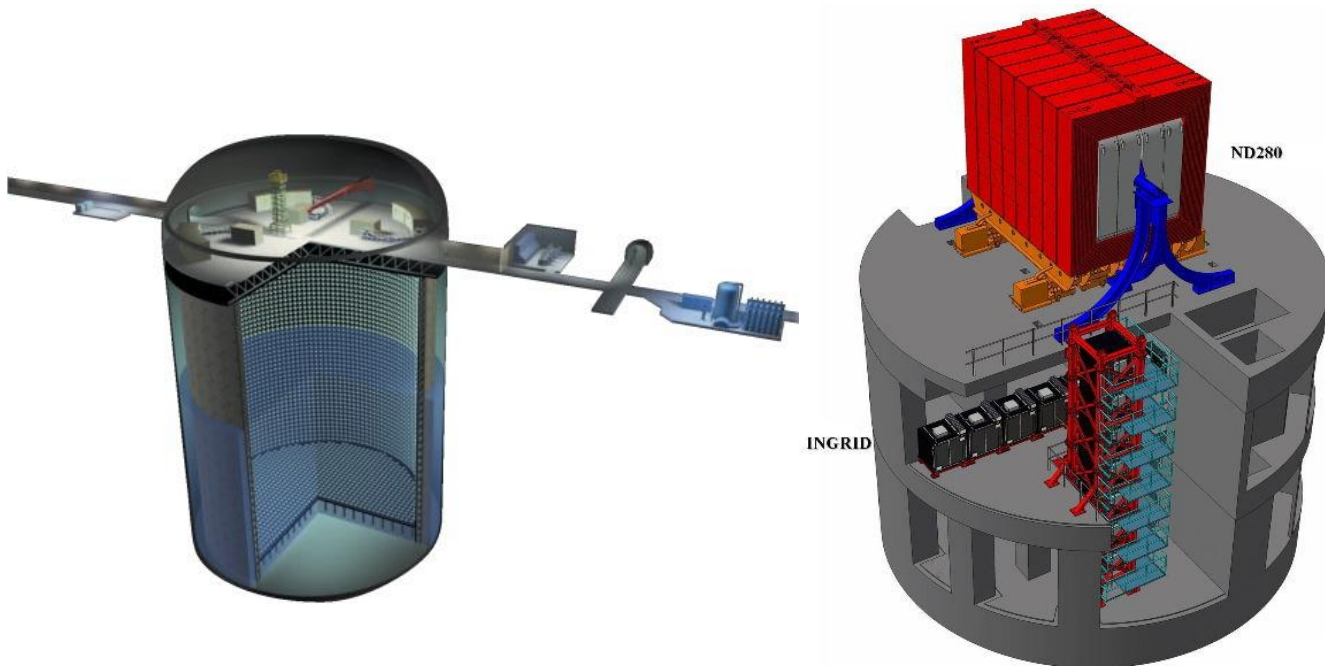

Between Tokai, Japan and Super-Kamiokande

$\nu_\mu/\bar{\nu}_\mu$ beam to measure $\nu_\mu/\bar{\nu}_\mu$ disappearance and $\nu_e/\bar{\nu}_e$ appearance

Sensitive to δ_{CP} , θ_{23} and Δm_{23}^2

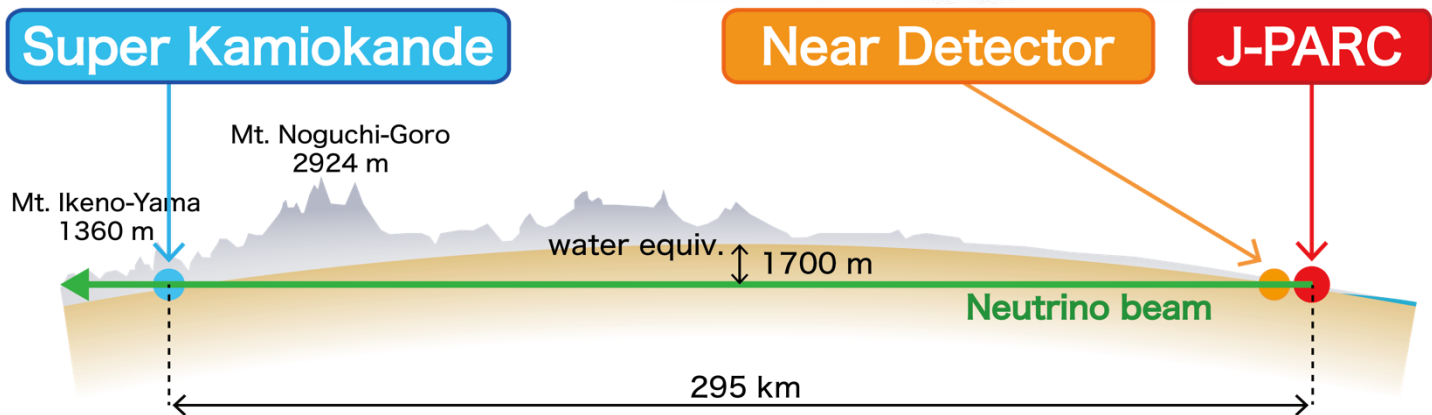

THE NEAR DETECTOR ND280

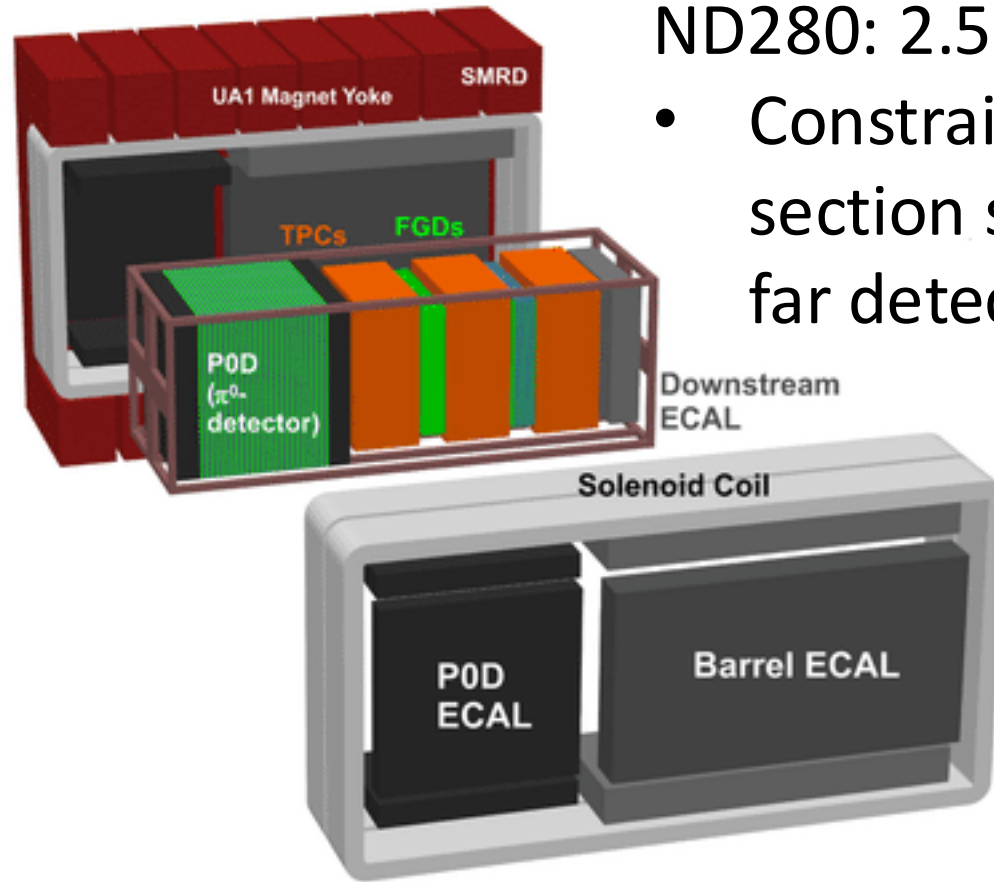
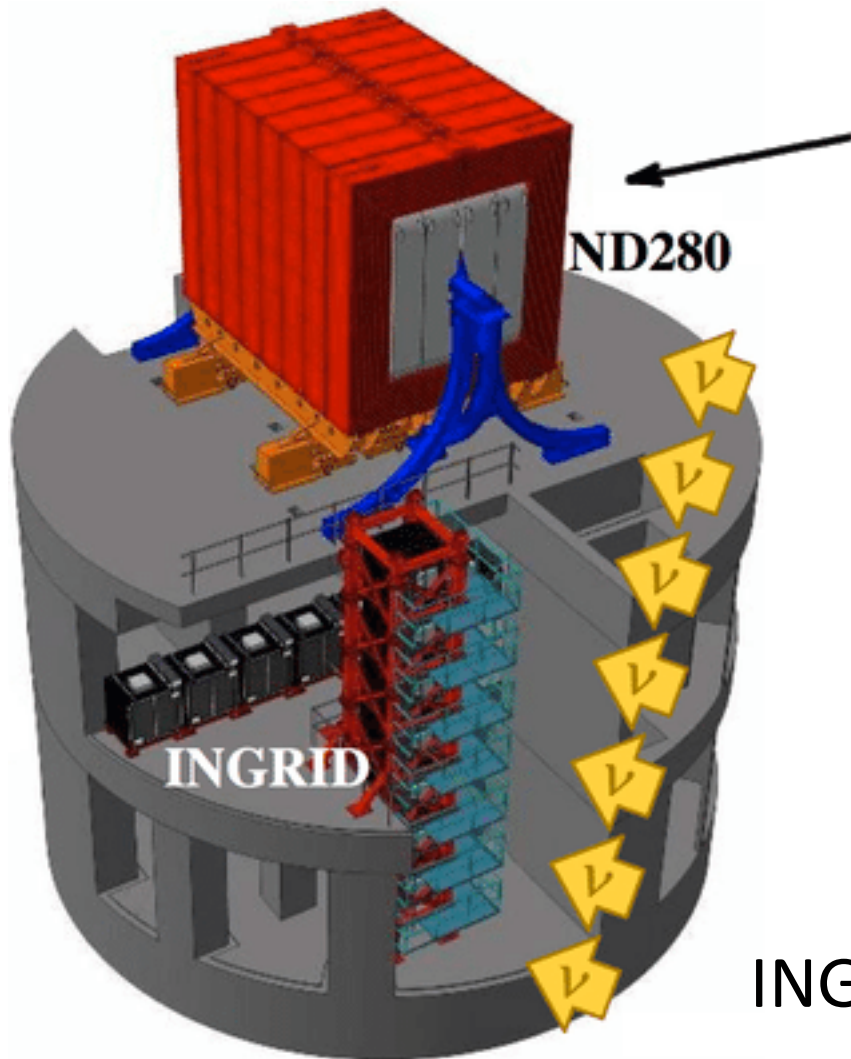

ND280: 2.5 degrees off-axis

- Constrains flux and cross-section systematics for the far detector

INGRID: on-axis, measures beam centre, direction

LIMITATIONS OF THE ORIGINAL ND280

- Mis-match in detected neutrino phase space, especially at high angle due to FGD inefficiency
- High proton detection threshold at ~ 500 MeV

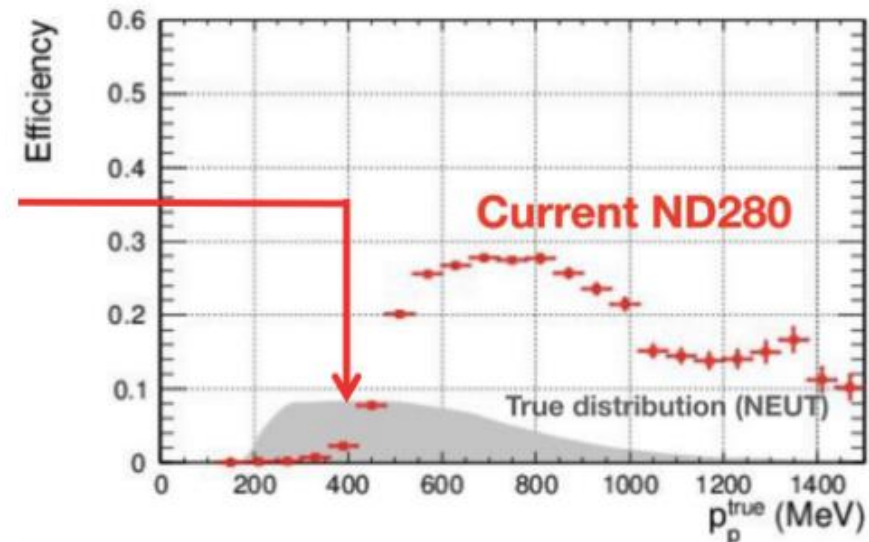
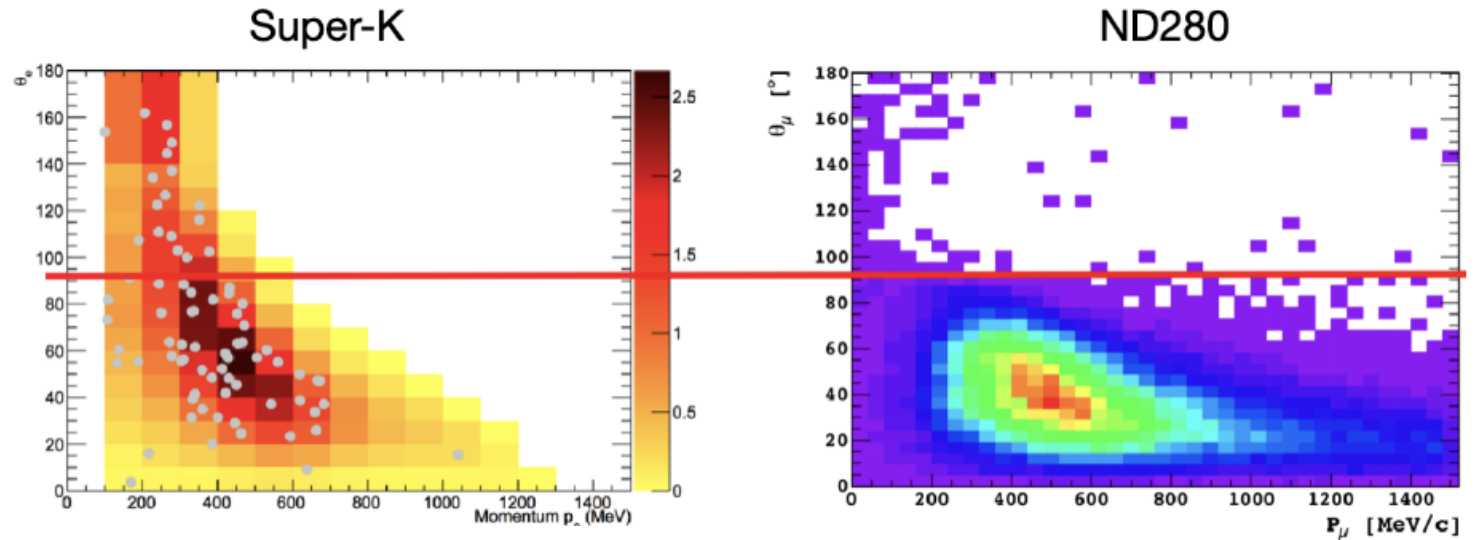

THE NEAR DETECTOR UPGRADE

3 new detectors replace the Pi-zero detector

- **Super Fine-Grained Detector:**

novel scintillator detector with 3D readout
(active target)

- **High-Angle TPC:**

tracking and PID for outgoing charged
particles from SFGD

- **Time-of-Flight (TOF):**

~100ps level timing resolution, vetoing and
cosmics trigger for upgrade

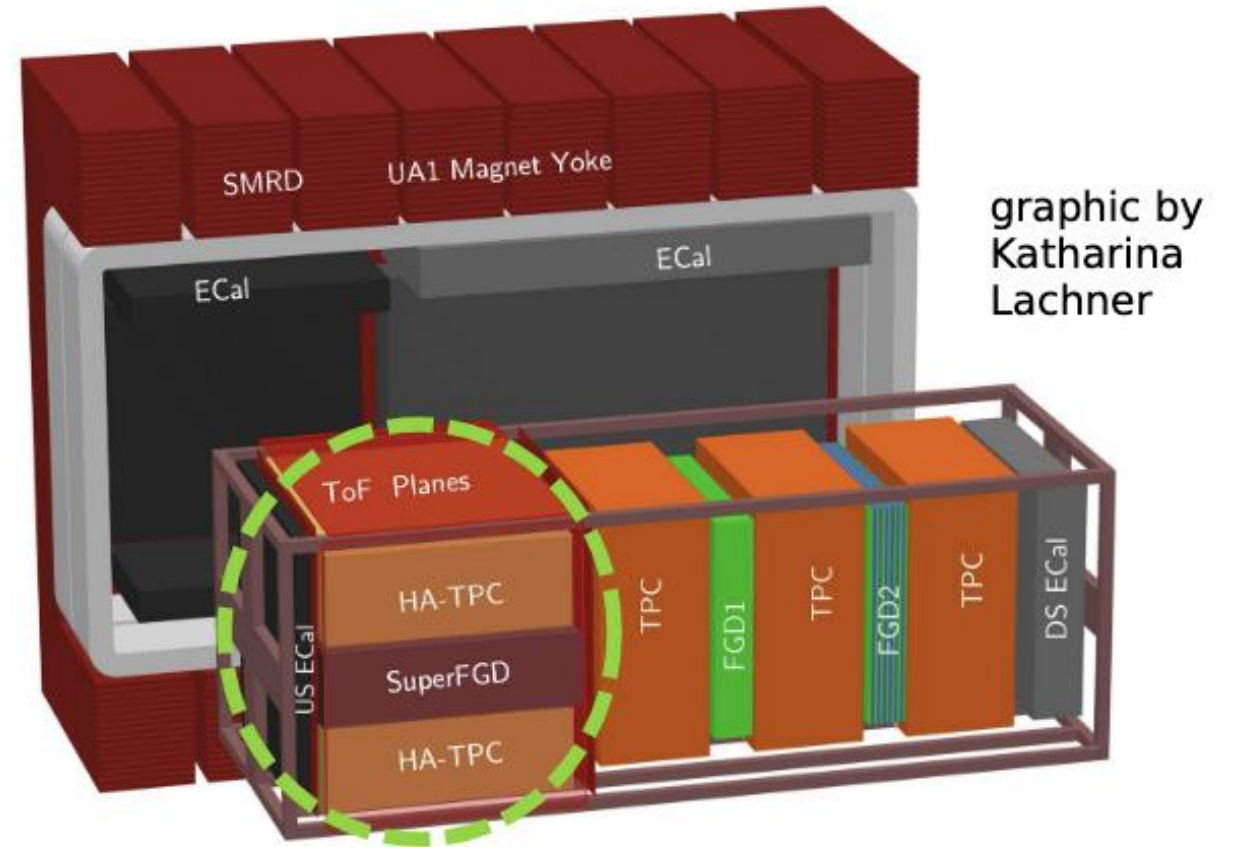

SUPER-FGD (THE CONCEPT)

- Instead of scintillator bars, we use 1x1x1cm scintillator cubes with reflective coating
- Cubes are traversed by wavelength shifting fibres in 3D
- SiPMs(Hamamatsu MPPCs) at ends of the fibre readout signals

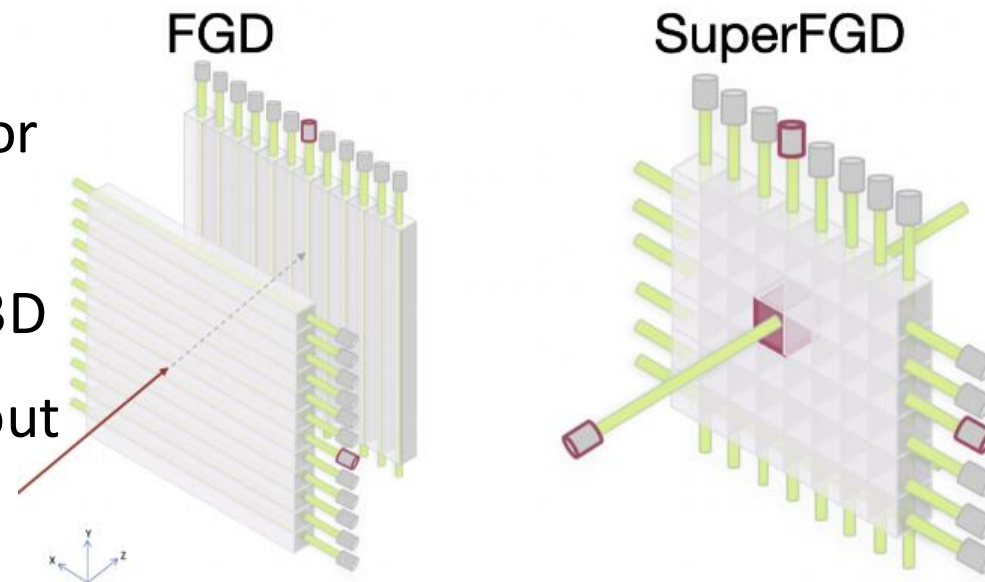

Benefits:

- Good acceptance even at high angles
- Highly granular 3-D tracks
- Fast readouts of time/charge of individual cubes via fibres
- Good resolution of vertex position and time
 - can reconstruct neutron kinematics event-by-event... (first time in HEP!)

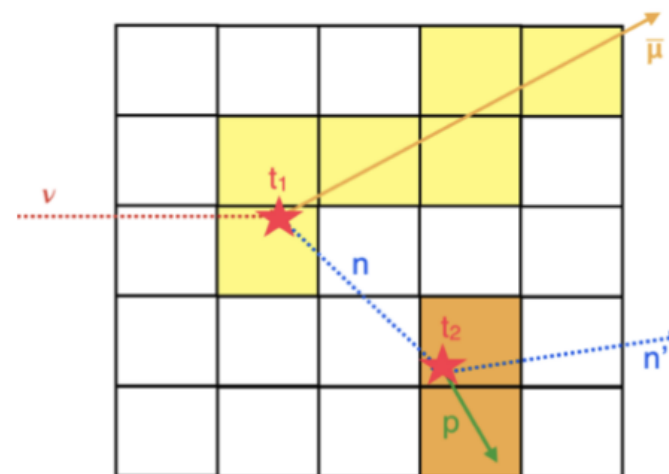

SUPERFGD PROTOTYPE & TESTING

- 2 Prototypes were built and tested at CERN (muons) and LANL(neutrons)

SuperFGD Prototype
3 types of MPPCs for
performance comparisons

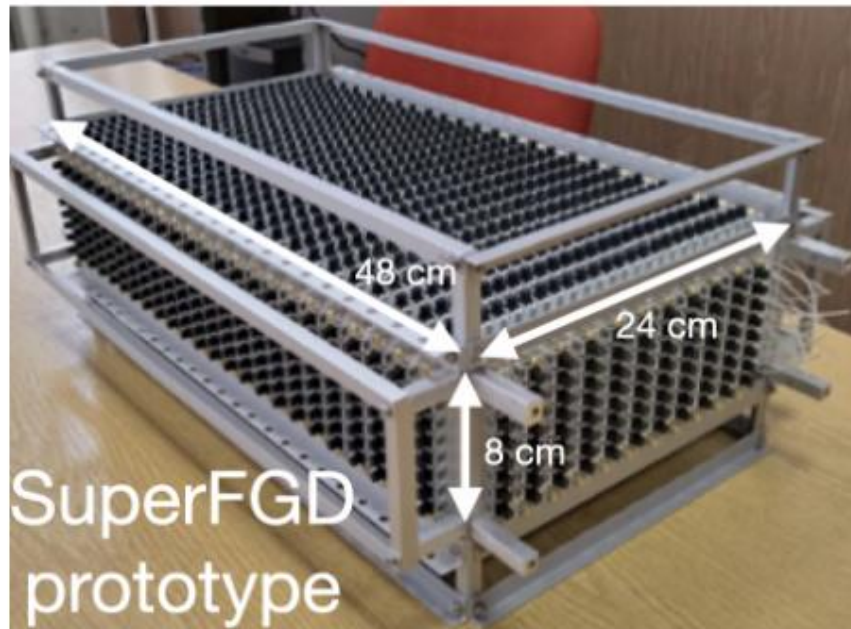

US-Japan prototype:



Much smaller, 1 type of MPPC

LANL NEUTRON TEST

- In 2019, the SFGD prototype was exposed to neutron test beam at Los Alamos National Lab

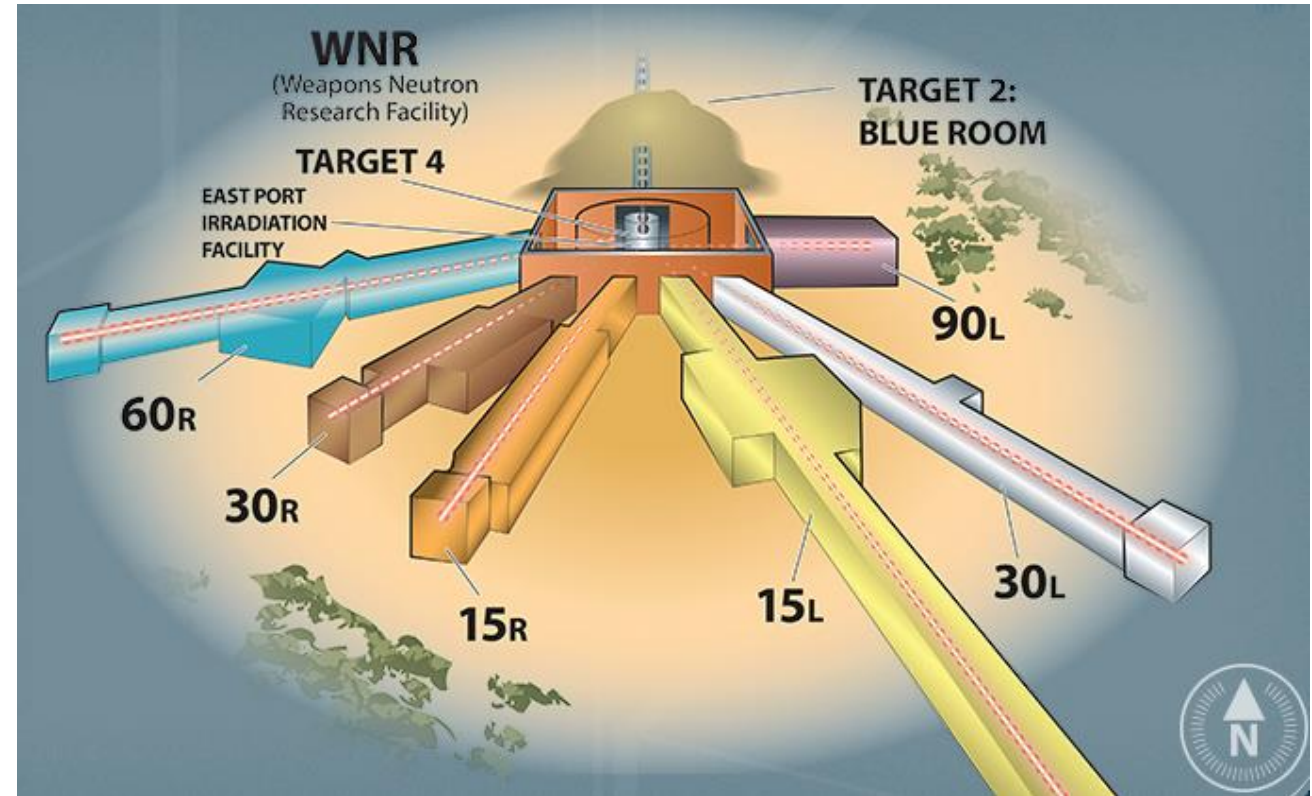
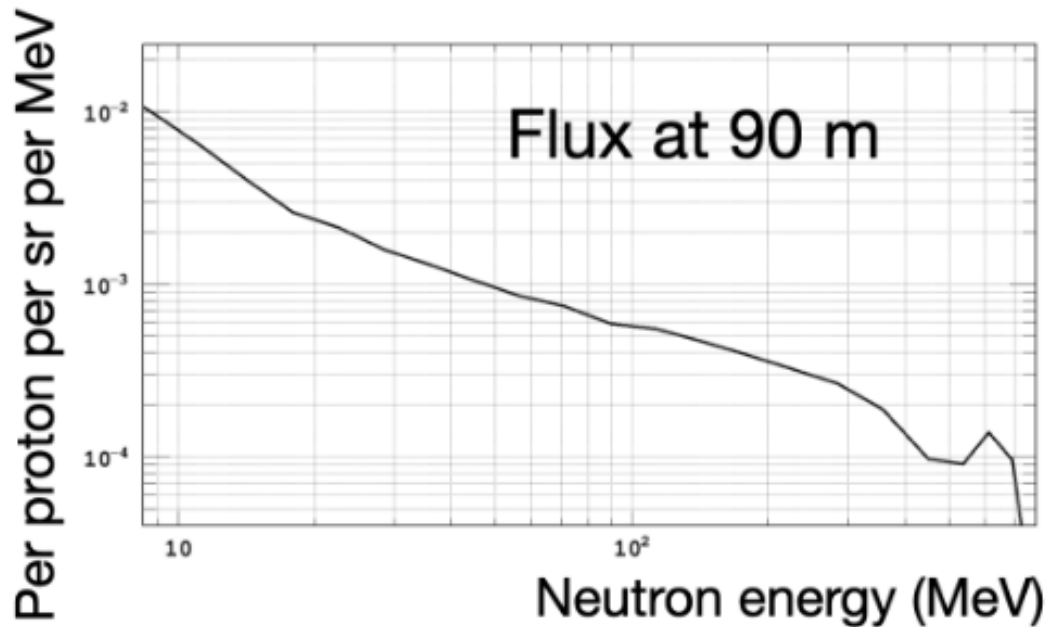

LANL NEUTRON TEST

- In 2019, the SFGD prototype was exposed to neutron test beam at Los Alamos
- Results used to show capability to reconstruct neutrons using time of flight

Gamma peak

neutron
interaction

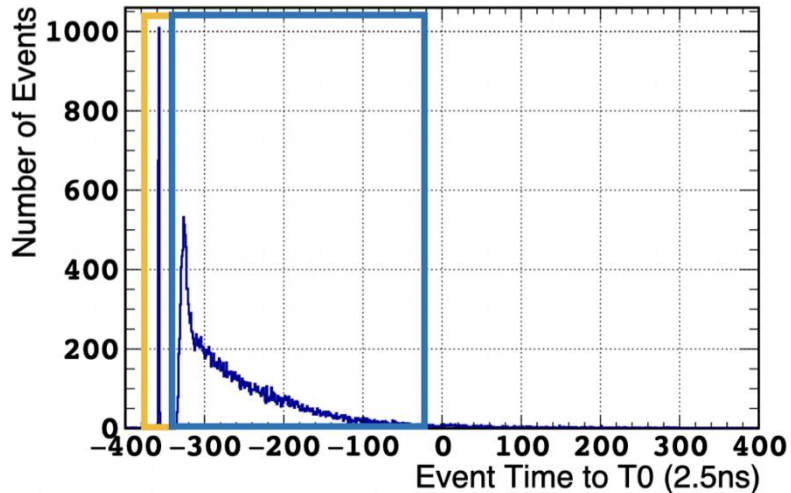

Total neutron cross-section vs. neutron energy

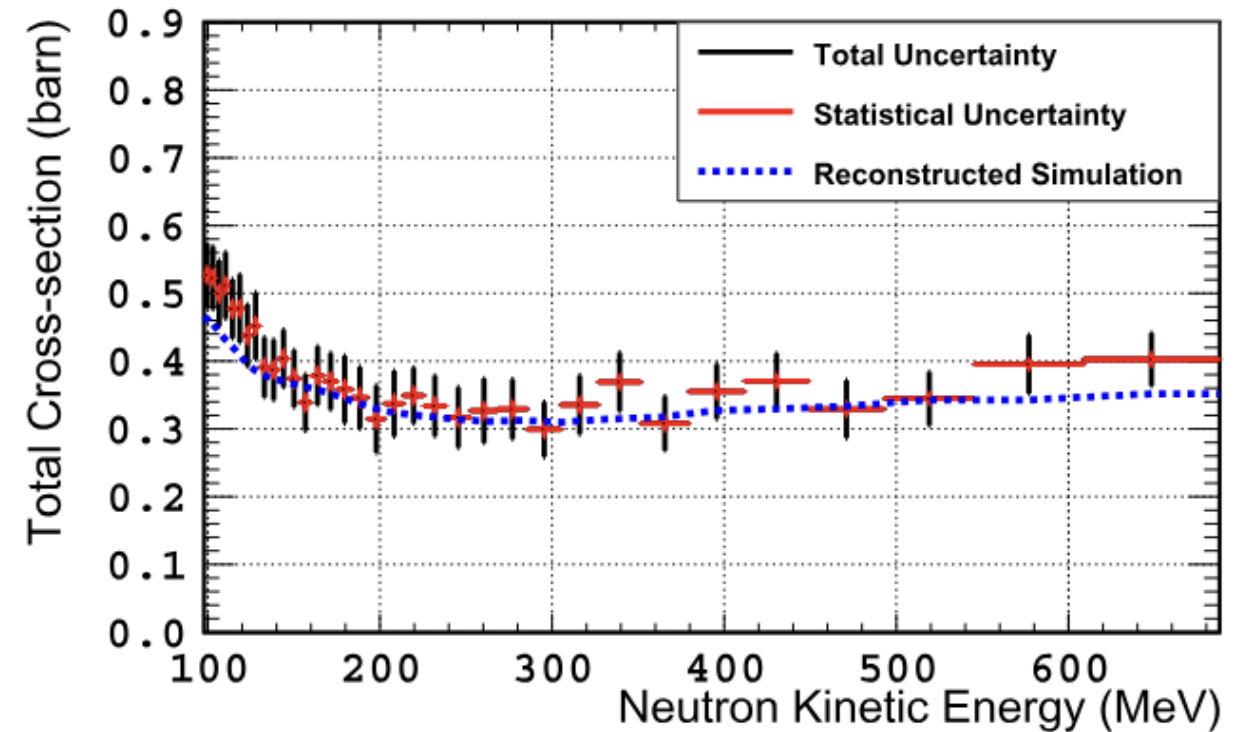

Agarwal, A., Budd, H., Capó, J., Chong, P., Christodoulou, G., Danilov, M., ... Zilberman, P. (2023). Total neutron cross-section measurement on CH with a novel 3D-projection scintillator detector. *Physics Letters B*, 840, 137843. doi:10.1016/j.physletb.2023.137843

SUPER-FGD (REAL DESIGN)

- $2\text{ m} \times 0.6\text{ m} \times 2\text{ m} \rightarrow 2\text{ ton}$ fiducial mass
- ~ 2 million cubes in total
- $\sim 56\text{k}$ MPPC channels (Hamamatsu 13360-1325PE)
- Scintillator cubes mass produced by INR, Russia
- Assembly on site at J-PARC, Tokai, Japan

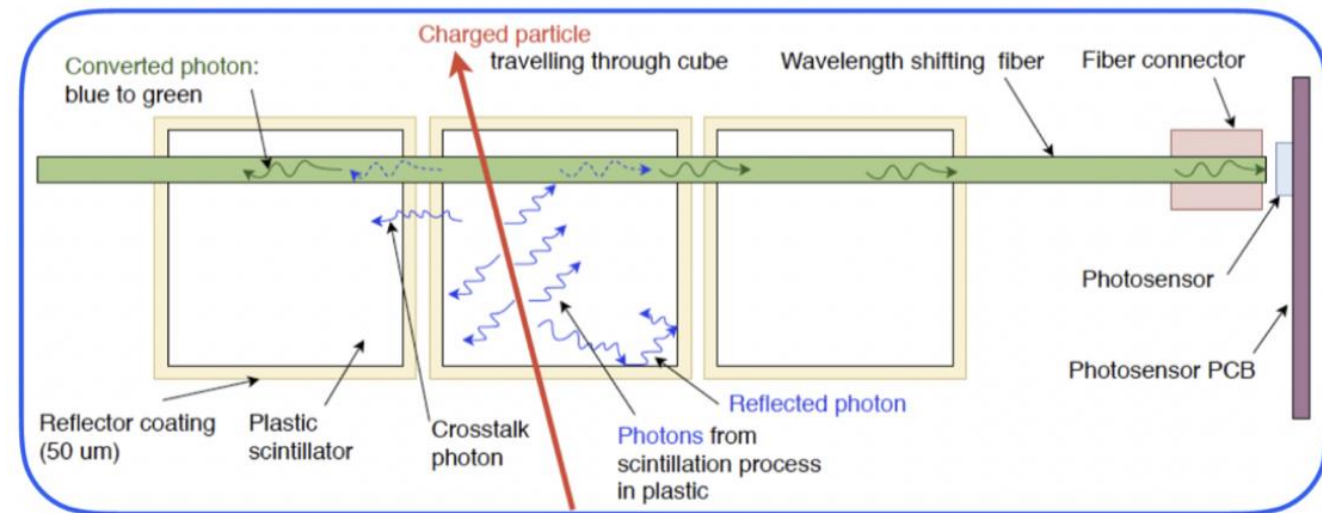
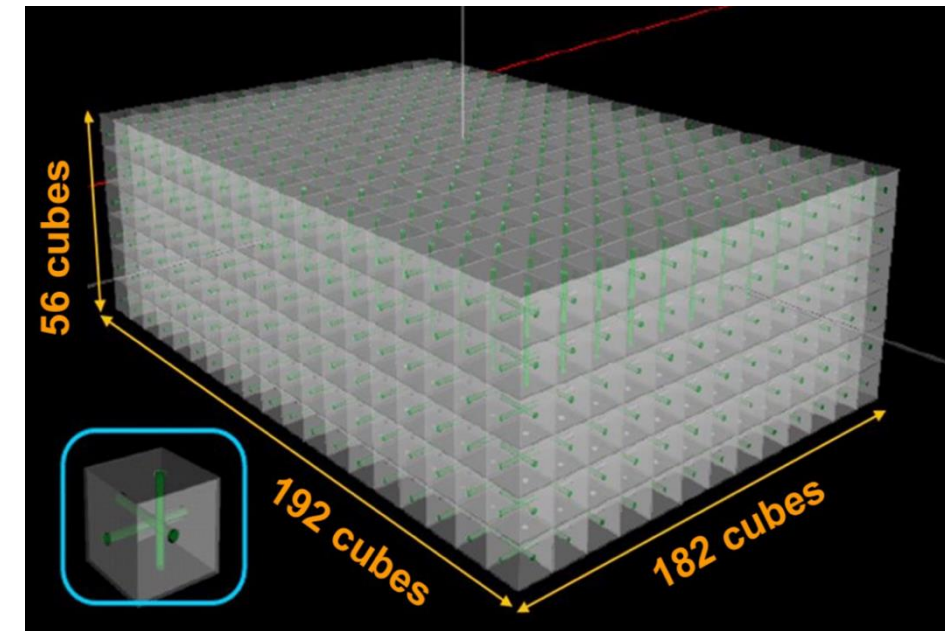
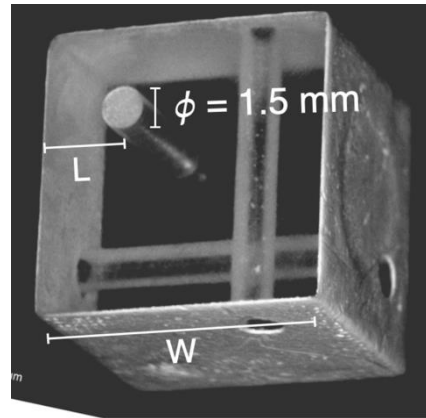

ASSEMBLY AND COMMISSIONING

- Assembly took place at J-PARC in Tokai, Japan in Summer 2023
- Detector was fully assembled with most electronics in Dec 2023
- Electronics finished in April 2024



Many Stony Brook members!

Commissioning and Installation

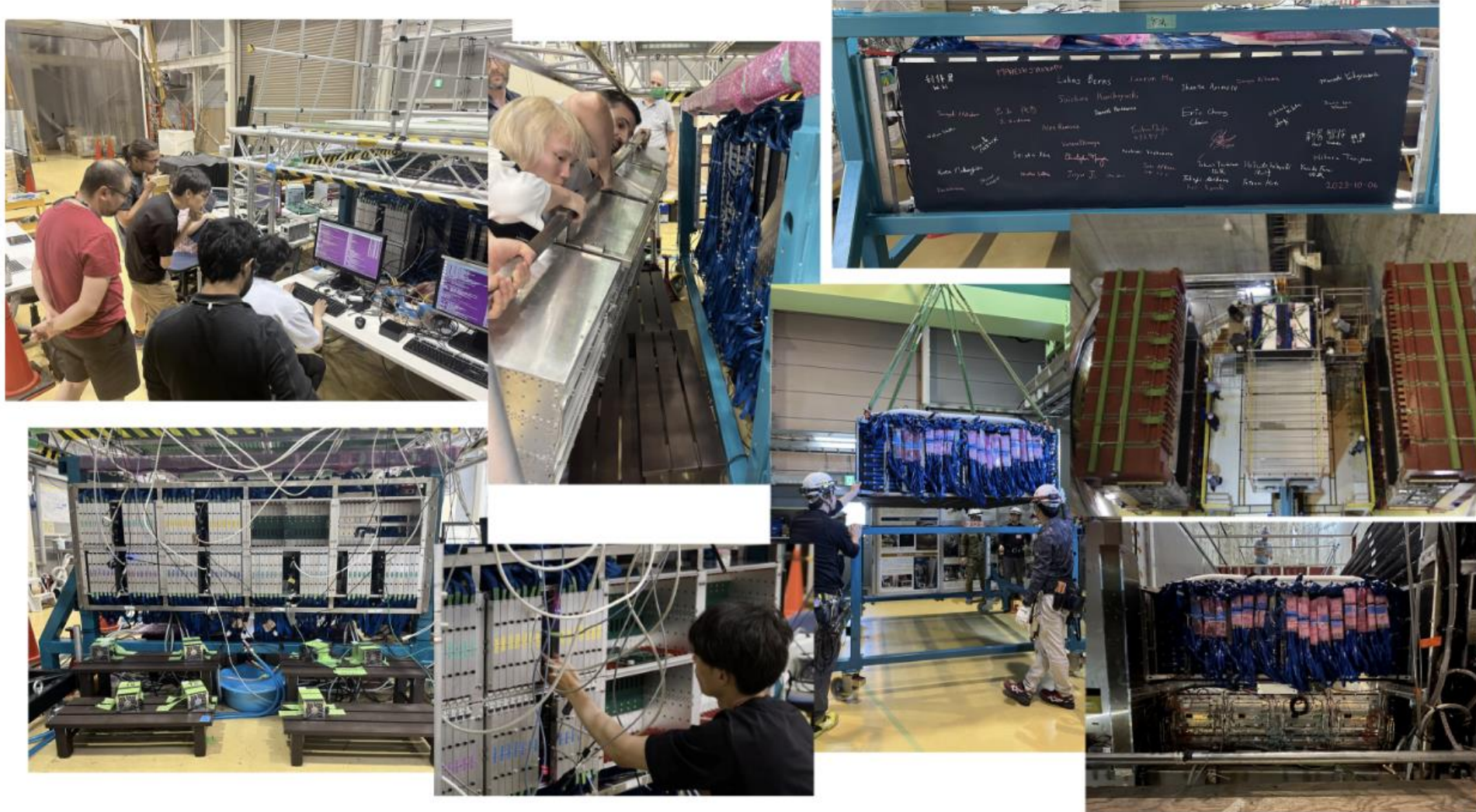

From T.Doyle's talk at NuFact 2024

ELECTRONICS & CALIBRATION

Main Clock Board

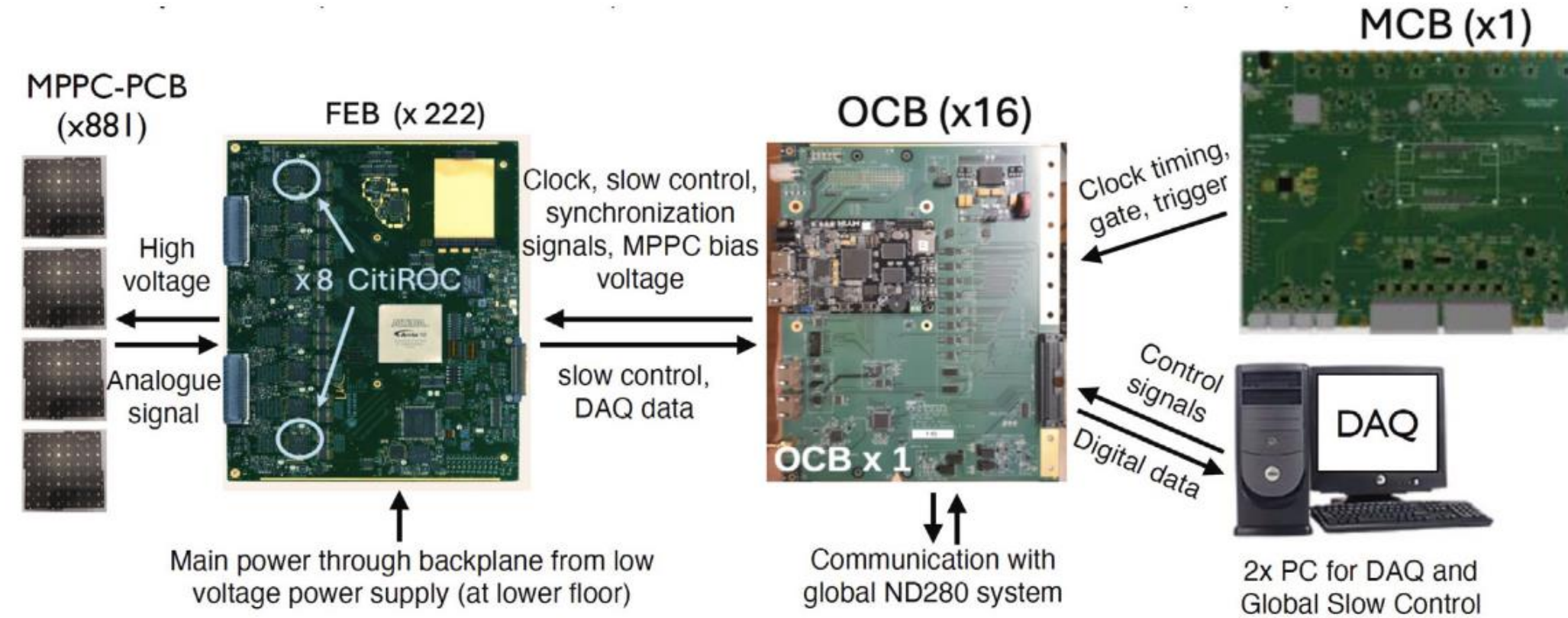

MPPC

Front-end Board

Optical Control Board

ELECTRONICS & CALIBRATION

3 Shapers on a CITIROC channel:

- High gain (HG) ADC
- Low gain (LG) ADC
- TDC

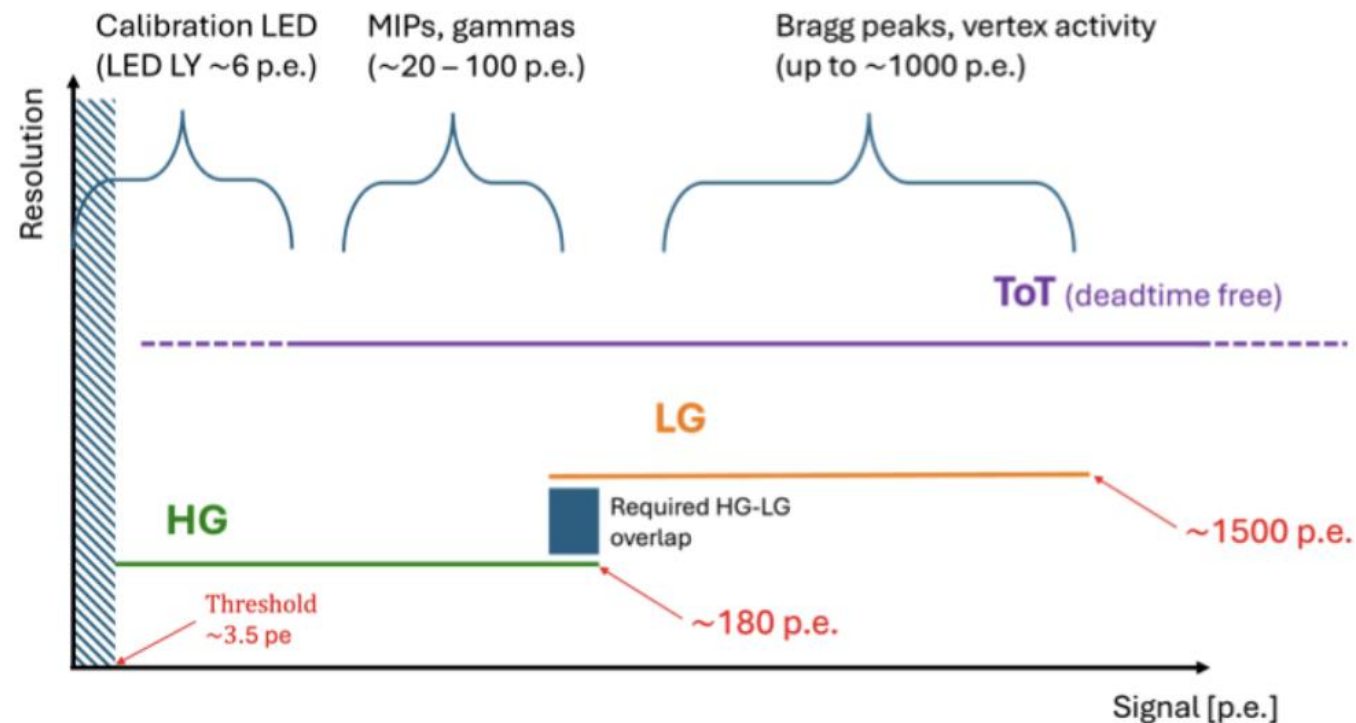

We use these to infer charge & time of the arrived signal

- Low charge -> HG
- High charge -> LG
- ADC Deadtime after pulse -> Time-over-threshold

LED CALIBRATION

- LED injectors at the opposite ends to MPPC inject small light signals
- The result HG ADC distribution known as “finger plot”
- Fit the distance between fingers and the 1st (pedestal) peak to recover gain and pedestal for HG shaper

LG calibration from ADC ratio with HG via cosmics data

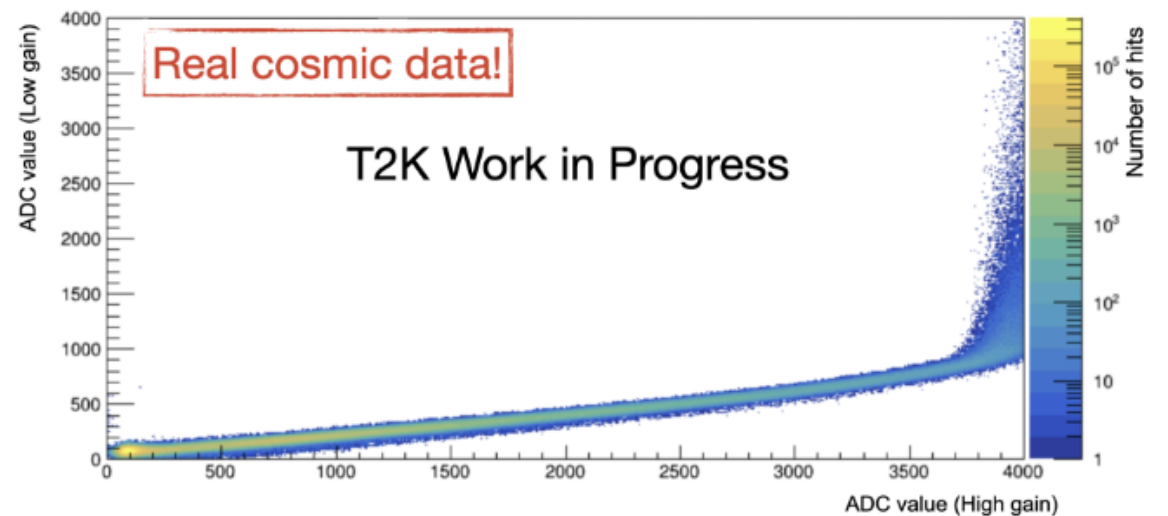
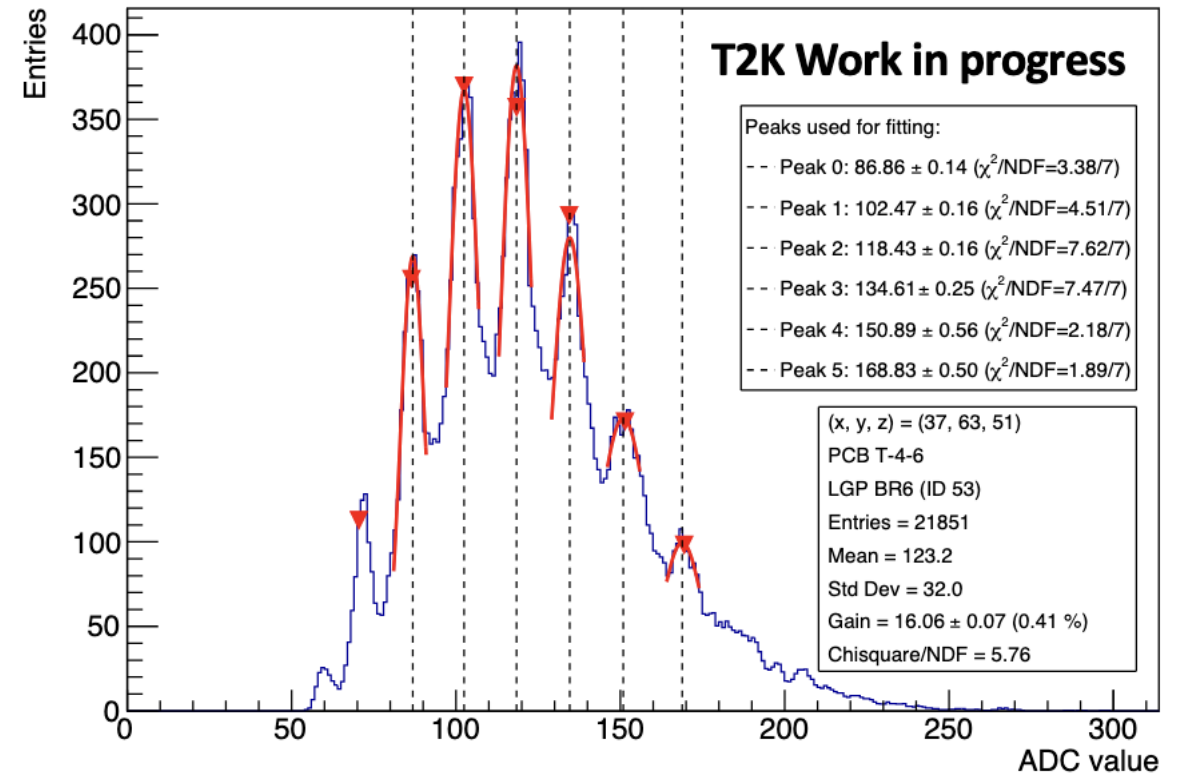

SFGD TIME CALIBRATION

- Unlike prototype, reconstruction of neutrons from neutrino vertex requires 2 vertices
- Neutrons travel $\sim 30\text{cm}$ before stopping
→ sub-ns cube time resolution needed to reconstruct kinematics
- 3 fibres will readout different times due to:
 - Different fibre lengths (can be compensated)
 - Different Time-offsets between MPPC channels
 - Time-walk

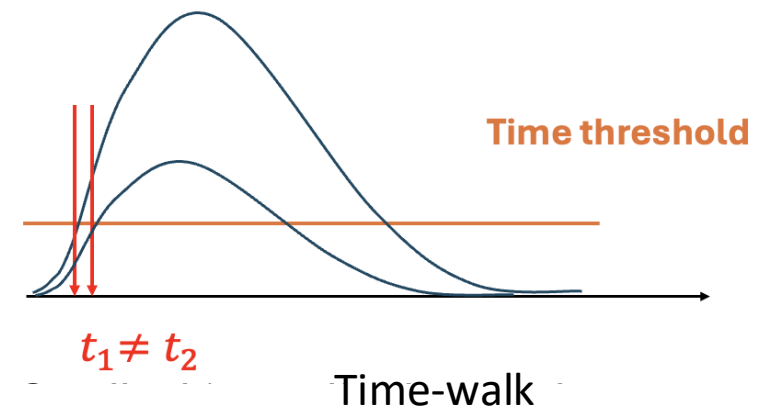
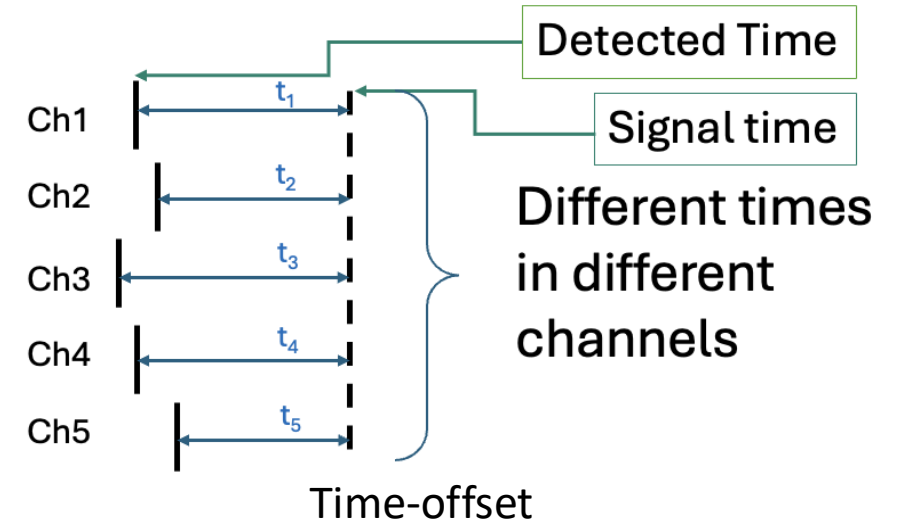

NOVEL ITERATIVE TIME CALIBRATION FOR SFGD

- Correcting time-offsets typically require cosmic tracks & reference points
- We employ an iterative algorithm to solve for offsets using time-difference between matched hits
- Time offsets result in time-differences between fibre times for the same cube
- Expect the average time-offset for many channels to be 0
- Solve for channel offset iteratively by averaging over time-difference with many other channels

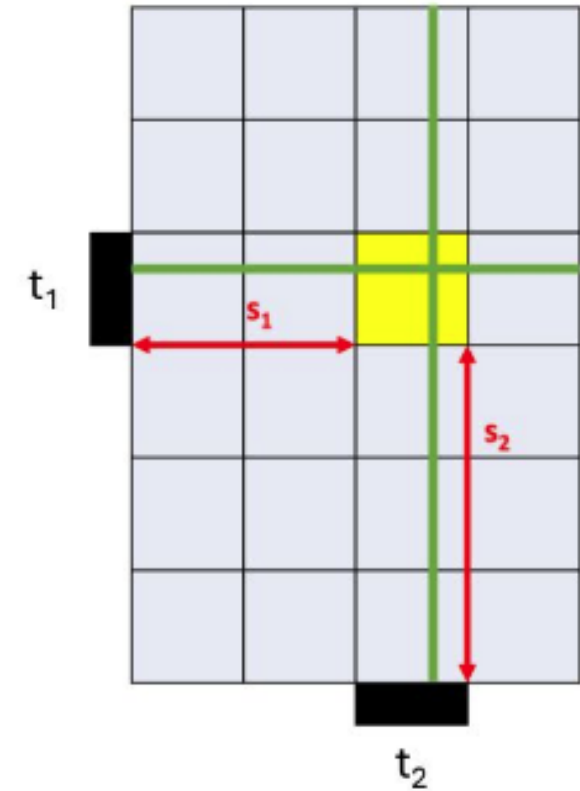

L. Giannessi, V.S. Kasturi, G. Reina, H. Zheng et al 2025 *JINST* 20 P10030

TIME CALIBRATION FOR SFGD

Result:

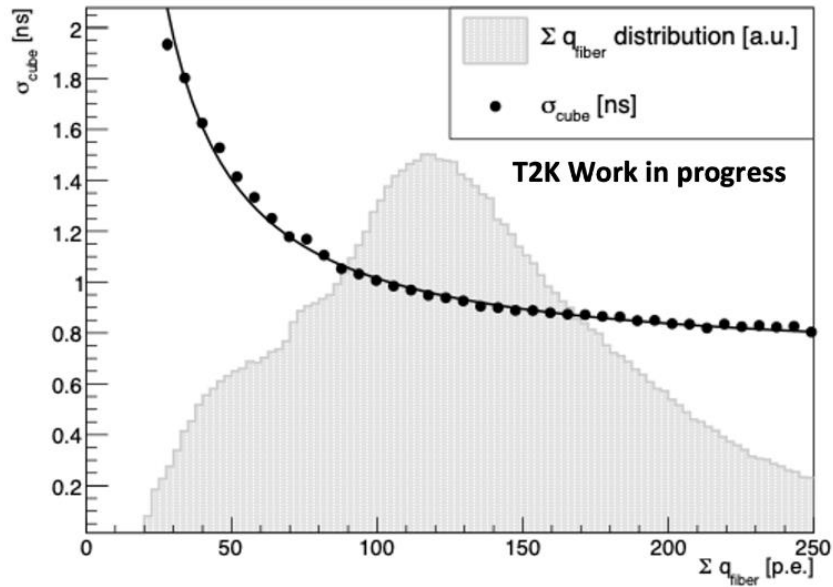

Sub-ns cube time resolution for MIP like deposits

Time-walk characterisation

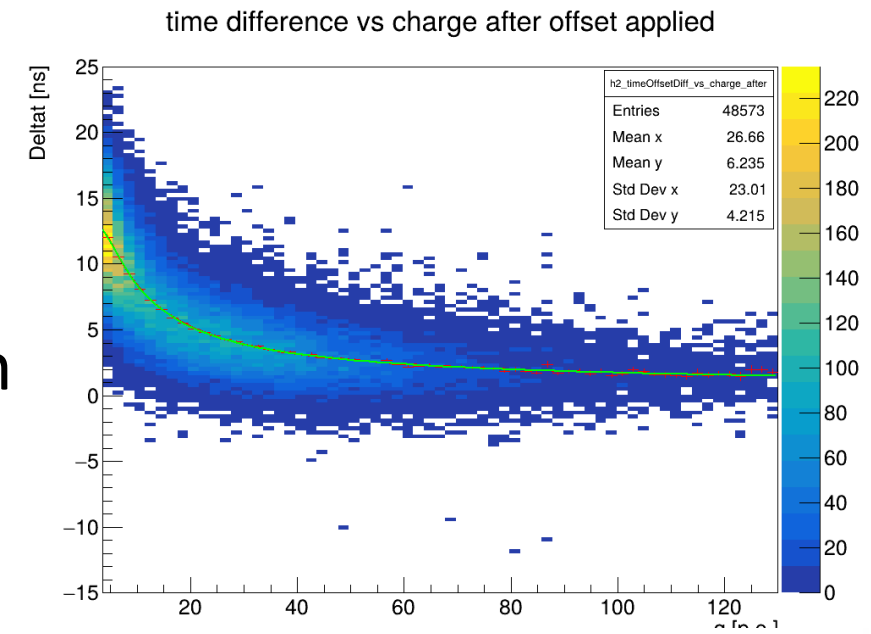

Time-offset map

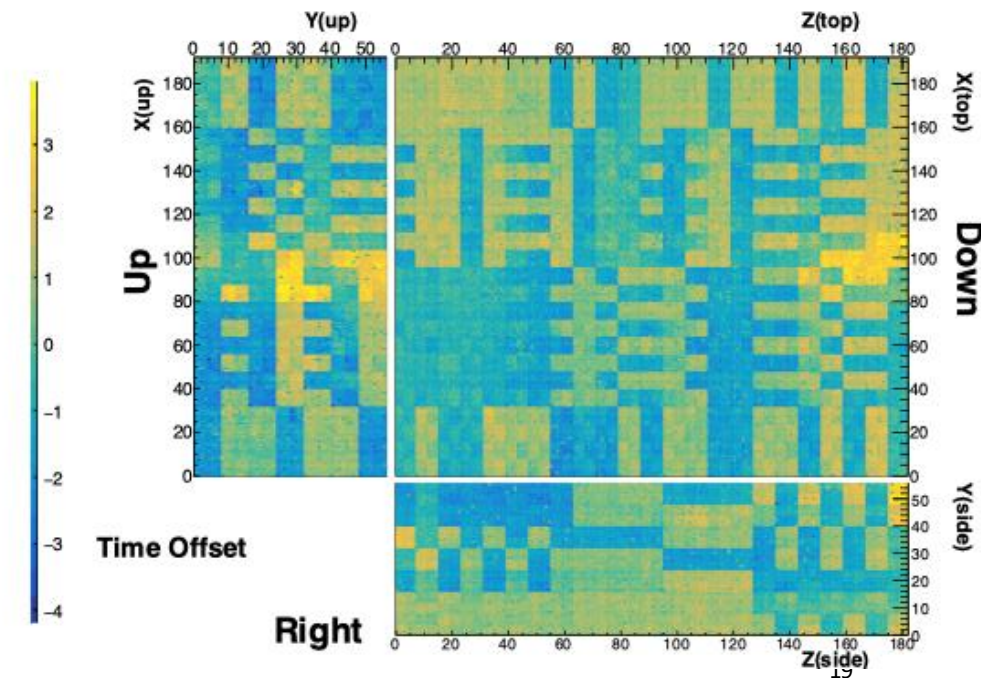

DETECTOR PERFORMANCE

- We characterise the detector to reconstruct tracks/vertices from detector output and tune or Monte Carlo simulation

Fiber light attenuation curve

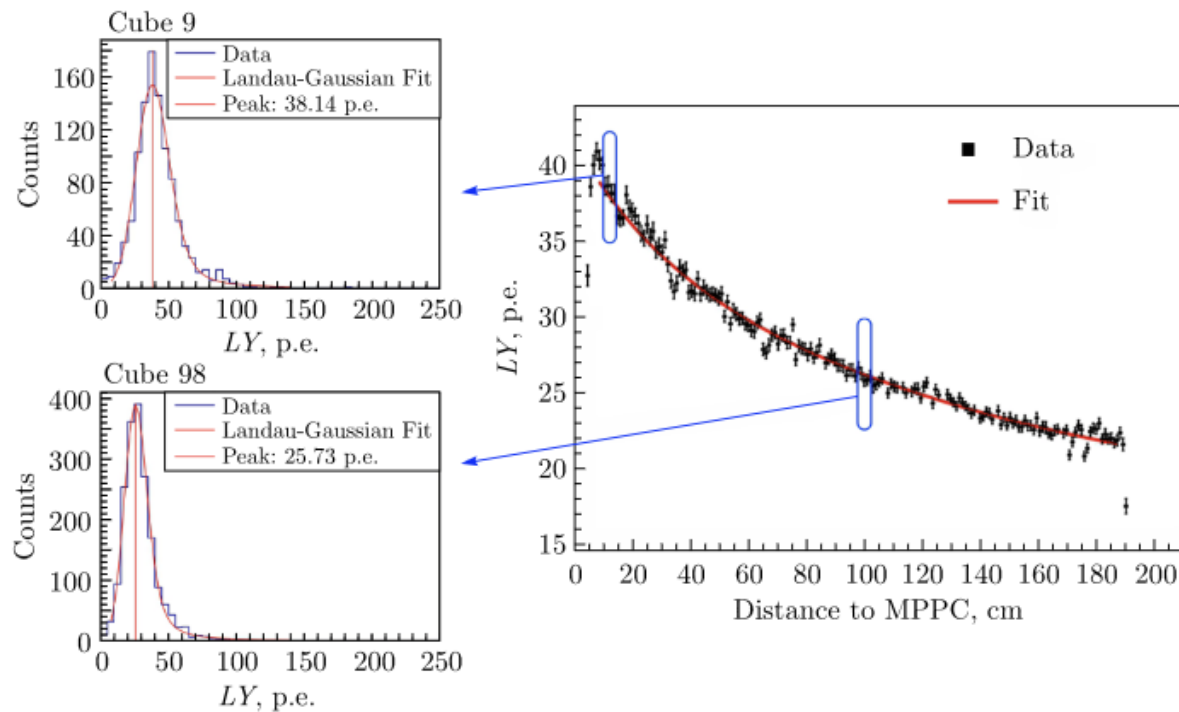

Used to find cube charge from fibre readout

Channel quality map

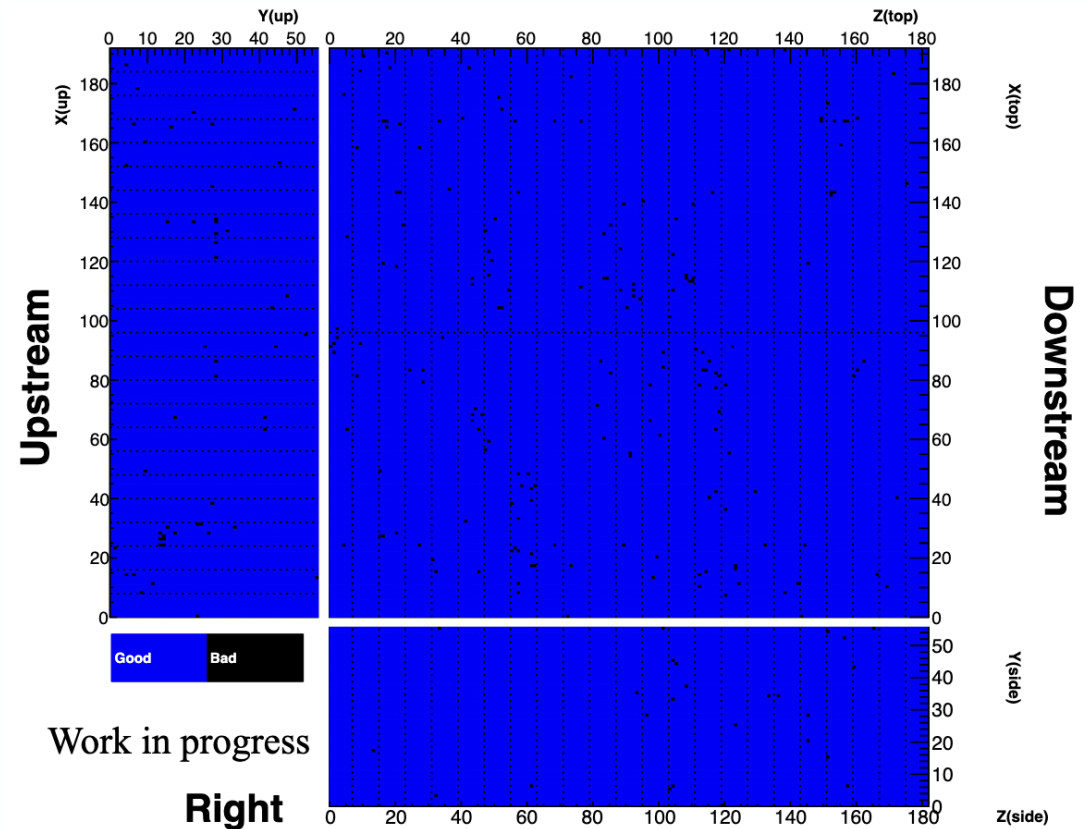

DETECTOR PERFORMANCE

Cube cross-talk (light leak) $\sim 3\%$

Optical crosstalk between scintillator cubes

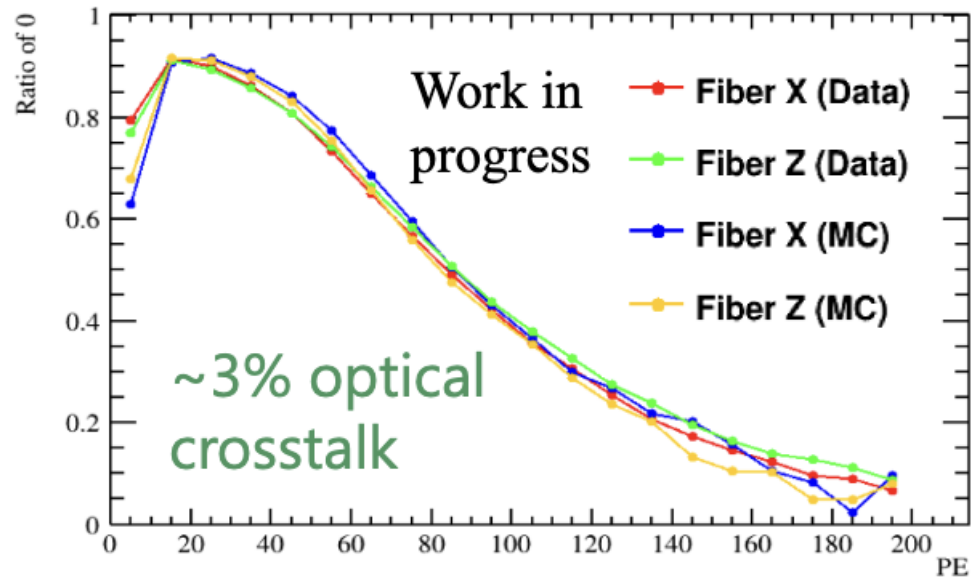

Stopping proton analysis

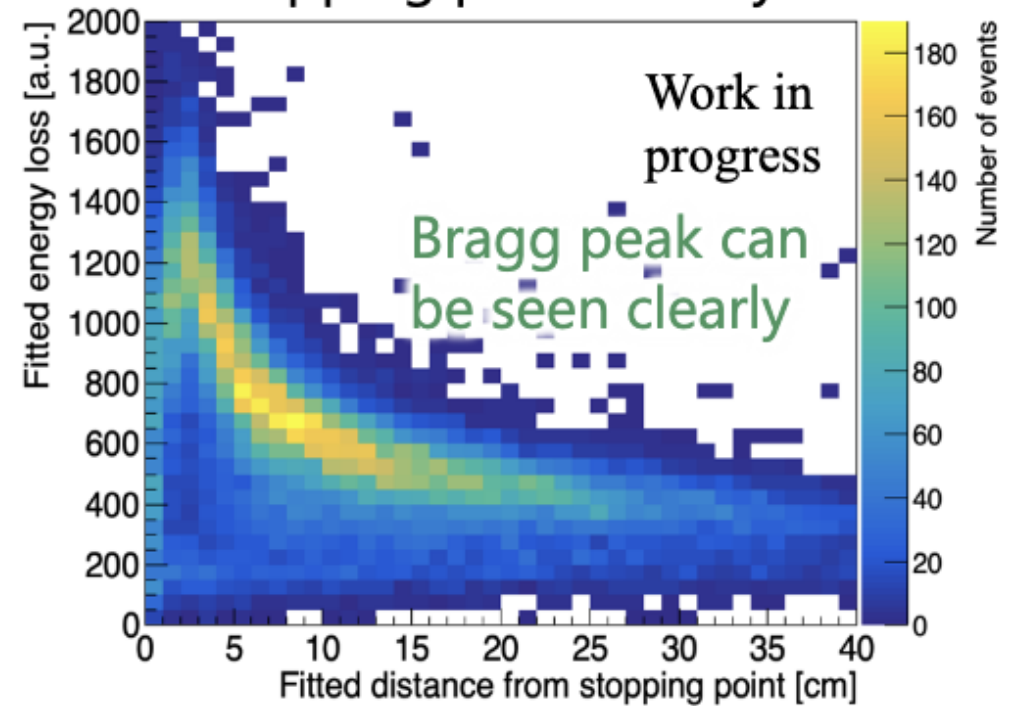

SOME EVENT DISPLAYS

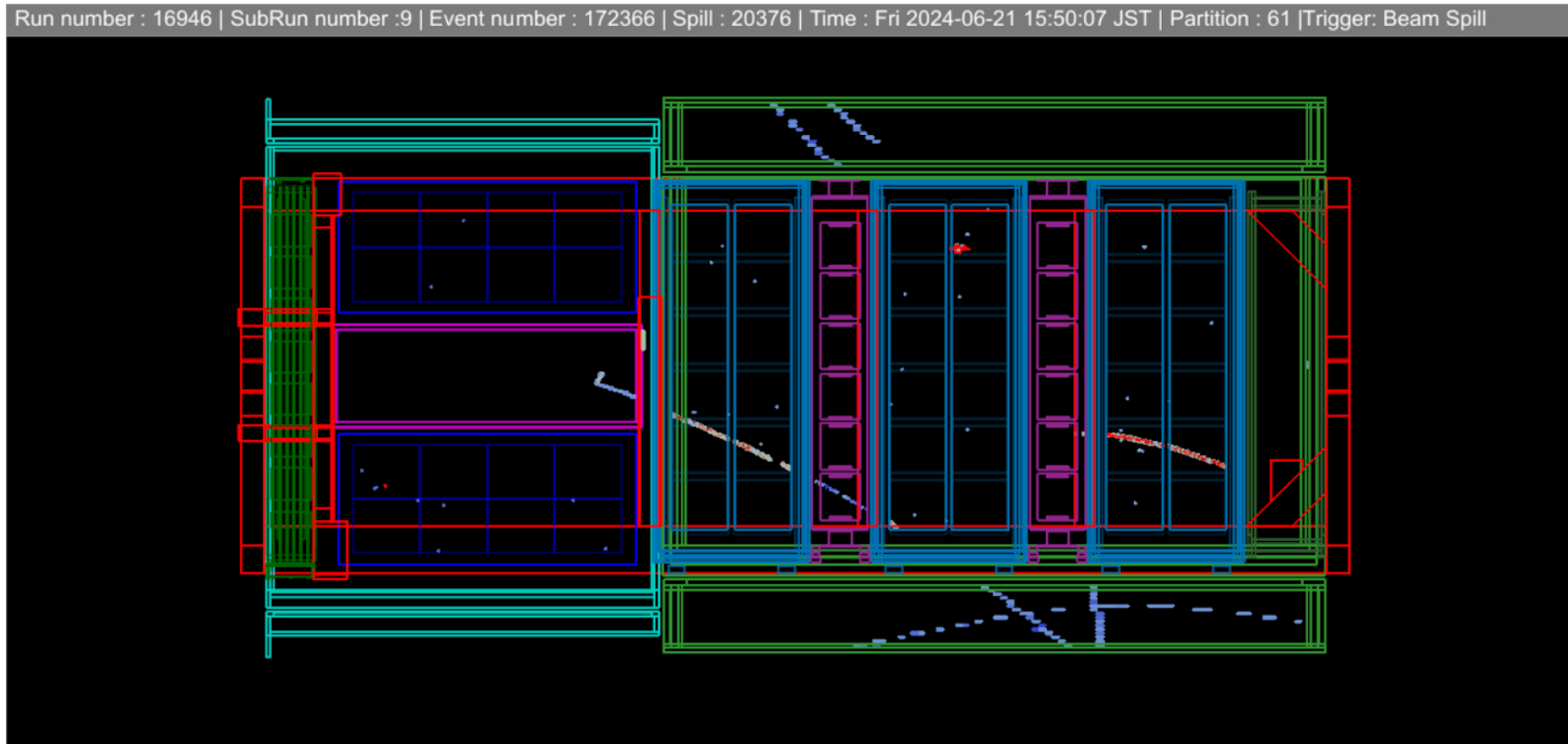

Neutrino interaction (muon + proton) candidate in SFGD

SOME EVENT DISPLAYS

Event number : 345342 | Run number : 16847 | Spill : 28852 | Time : Fri 2024-06-07 18:29:00 JST | Trigger: Beam Spill

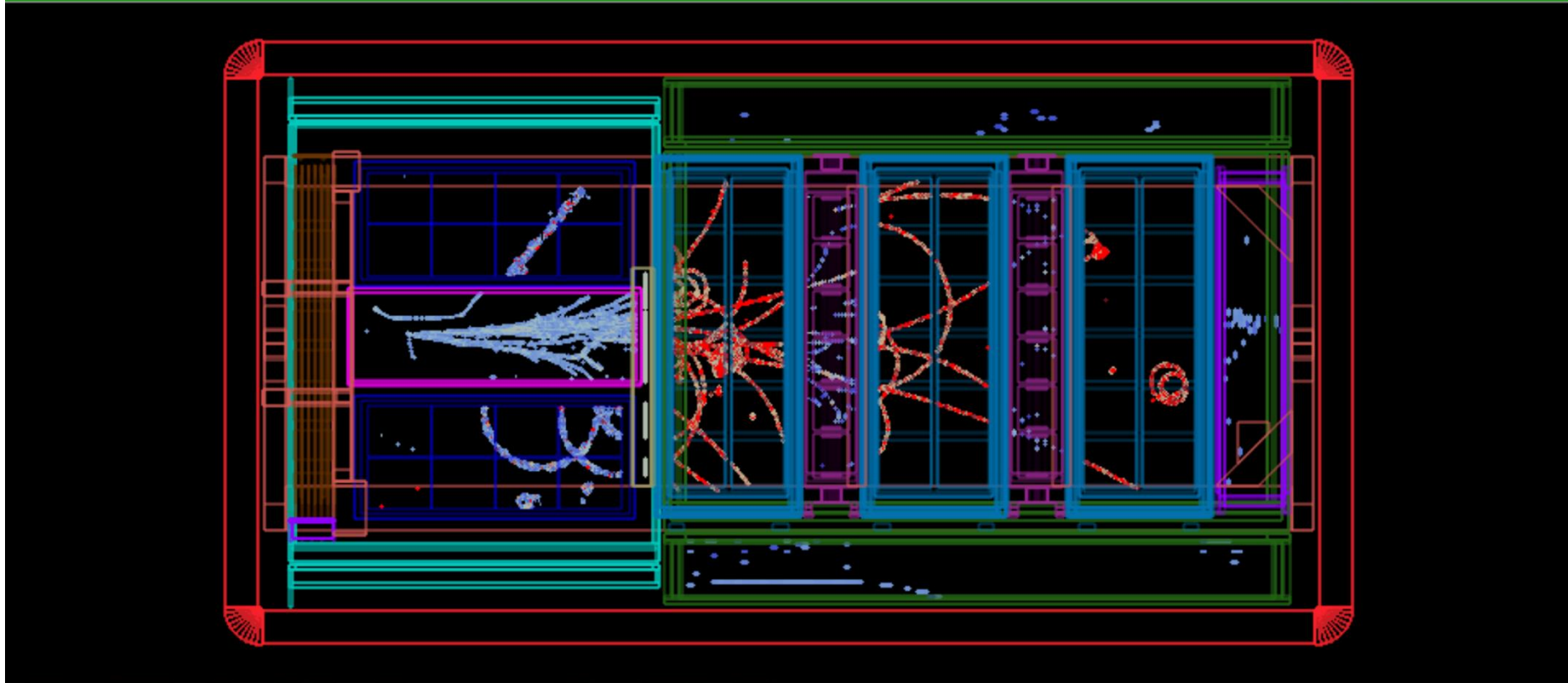

Neutrino Deep Inelastic Scattering candidate

SOME EVENT DISPLAYS

Run number : 16950 | SubRun number : 11 | Event number : 220630 | Spill : 43358 | Time : Sun 2024-06-23 02:22:31 JST | Partition : 61 | Trigger: Beam Spill

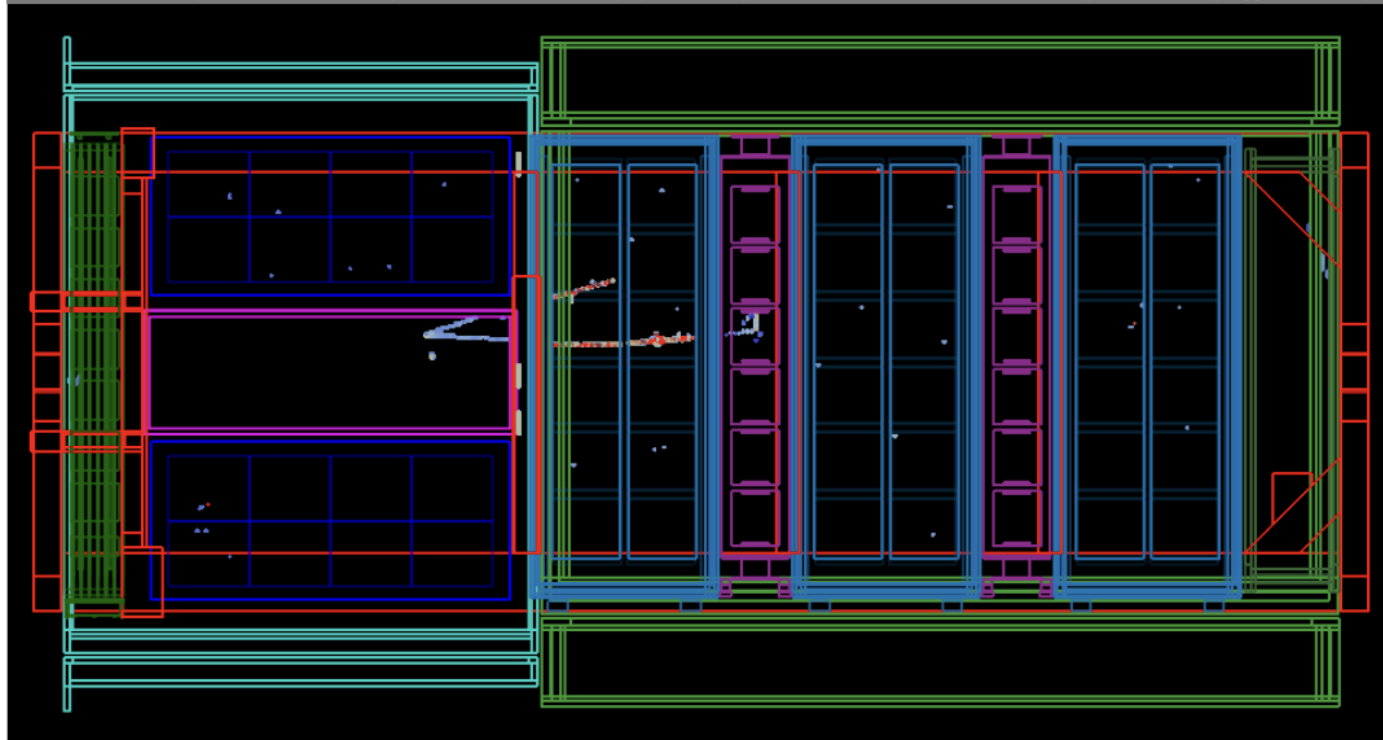

Lever arm = 122.28 mm

Time of flight = 1.73 ns

Kinetic energy = 27.3 MeV

Neutron event candidate

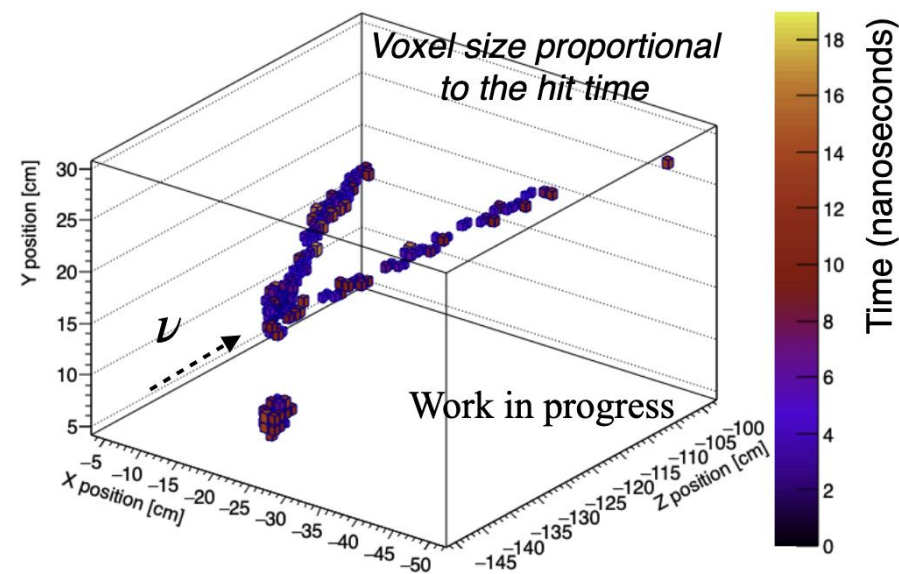
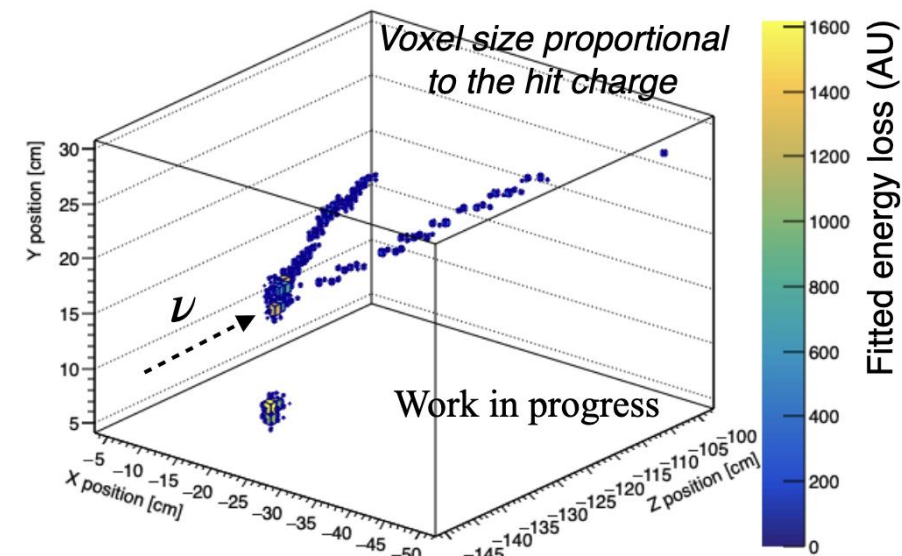

PHYSICS GOALS

- Analysis with ND280 upgrade is underway
- Some preliminary results are promising
- Simulated studies show what ND280 upgrade can achieve:

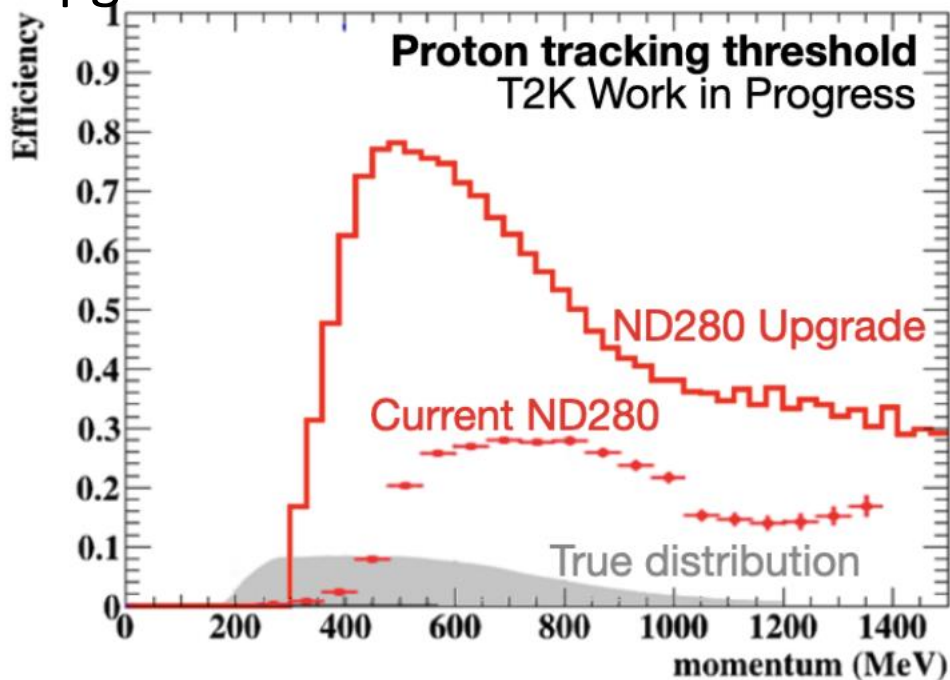

Lower proton threshold at $\sim 300\text{MeV}$

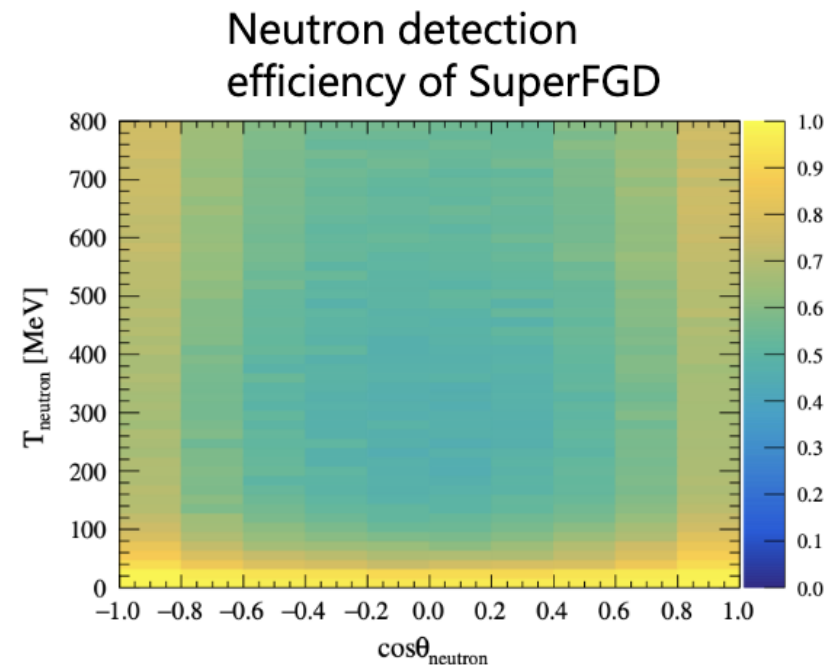

Neutron kinematics reconstruction

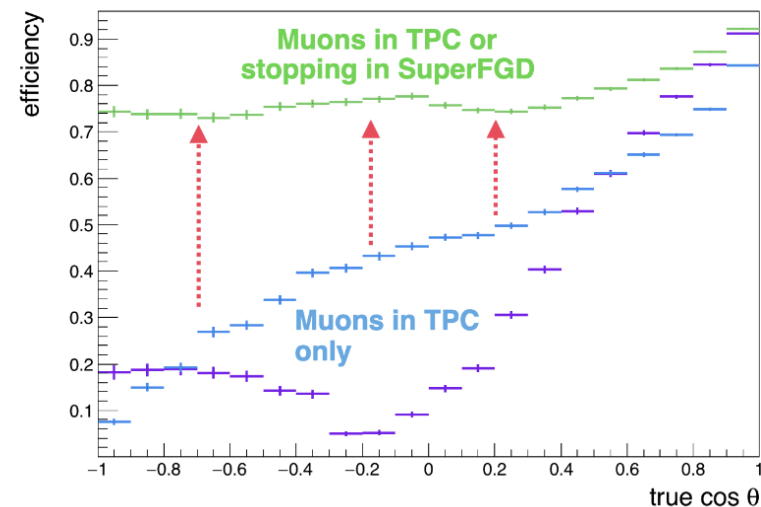

4Pi angular acceptance for muons

CONCLUSION

- Super-FGD has been successfully assembled & commissioned
- Detector Performance characterised as expected
- Novel time calibration technique used, applicable to a wider range of future detectors
- Early results indicate significant improvement, more analyses underway!

BACKUP

SFGD ASSEMBLY

